



## Method of Efficient Control of the Sucker-Rod Pump Electric Drive

---

Anatoly N. Ladygin, Dmitry D. Bogachenko, Nikolay A. Ladygin  
and Vladimir V. Kholin

EasyChair preprints are intended for rapid dissemination of research results and are integrated with the rest of EasyChair.

January 10, 2020

# Method of efficient control of the sucker-rod pump electric drive

Anatoly N. Ladygin, Dmitry D. Bogachenko,  
Vladimir V. Kholin

Department of Electric Drive  
National Research University "MPEI" Moscow, Russian  
Federation  
LadyginAN@mpei.ru

Nikolay A. Ladygin

Schnider Electric, Moscow, Russian Federation

**Abstract**— Results of designing of a control mode by the frequency-regulated electric drive of the sucker-rod pump with the induction motor are presented. The designing purpose is increasing energy efficiency of pump electric drive at the expense of electrical energy consumption decrease in a working cycle. Reducing energy consumption is achieved by using the kinetic energy of the unbalanced mechanical parts of the pump, which perform a reciprocating movement in a vertical plane. To implement this principle in a pump electric drive with frequency control asynchronous motor, it is proposed to use not a constant reference signal for the rotation speed of the motor shaft, but a periodically changing signal. In article is given the analytical substantiation of such solution. Mathematical expressions on which basis the speed reference signal should be formed, providing decrease in electrical energy consumption by the pump electric drive, are resulted. By means electrical engineering the expected effect can be provided by application of the special PLC, connected to the reference input of the frequency converter of the pump electric drive. Such PLC will perform the function of a specialized adjuster for the moving speed of the rod of the pump. The electric drive should be added by the position sensor established on a crankshaft of the pump unit and passing a signal about pump bar movement direction to the PLC of speed adjuster. At lowering of a pump rod the speed reference must be smoothly increase, providing growth of kinetic energy stock, and at lifting rod the speed reference must be smoothly decrease, providing the useful expense of kinetic energy stock. Thus, at use of an offered control mode the stream of energy, which is passing through the motor and the frequency converter at invariable volume of pump mechanical work, are decreases. So it defines increase of pump unit energy efficiency.

**Index Terms:** energy efficiency, variable speed drives, frequency convertor, sucker-rod pump.

## I. INTRODUCTION

Now one of the basic methods of an oil-production is its extraction from wells with the help sucker-rod pump units. Such units have higher efficiency, than centrifugal pump units, and under certain geological conditions it are unique suitable type of the oil pump [1].

Wide use of sucker-rod pumps and continuous growth of cost of the electric power, cause an urgency of search of ways of increase energy efficiency these installations set in motion by the electric drive [2, 3]. To be expected that even small improvement energy efficiency of sucker-rod pumps unit will give considerable economic benefit at oil-production.



Fig.1. Sucker-rod pump unit

## II. FEATURES OF A SUCKER-ROD PUMP UNIT DRIVE WORK AND BASIC POSSIBILITY OF POWER INPUTS DECREASE

Appearance of typical sucker-rod pump unit is presented on fig. 1, and its functional design is resulted on fig. 2. Unit consists of the mechanical design containing actually sucker-rod pump and the ground-based equipment, and the electric drive setting the mechanism in motion. Directly the sucker-rod pump itself represents the piston pump executed in the form of a pipe in 1m length 2-4m in which the piston-plunger 2 moves, in the length 1-1,5m. The plunger by means of the bars 3 located in a column of pipes 4, through the polished rod 5, is attached to a balance weight head 6 of the jack pump. The balance weight is set in motion by the driving electric motor 7. The torque from the

driving electric motor shaft 7, is passed through a belt drive and a reducer 8 on cranking pair 9. Thus rotary movement of a crank will be transformed to back and forth motion of the balance weight, bars and plunger the sucker-rod pump. On a crank shaft, as a rule, there is an additional balance weight.

The electric drive of modern sucker-rod pump installation represents itself system “the frequency converter (FC) – induction motor” [4,5] which allows smoothly regulate oscillation frequency and productivity of the pump. Well-known, that this function of the electric drive is very important for sucker-rod pump since target value of average speed of the electric motor, defining oscillation frequency of sucker-rod pump, in practice it is necessary to vary depending on geological characteristics of a well

It is simple to notice, that at a considered design of the pump mechanical loading of its electric drive in a pumping cycle current has obviously expressed variable character [6,7,8]. This feature of loading explain presence of unbalanced weights in a design of sucker-rod pump unit which are required to be lifted and lowered on each oscillation cycle. Thus, in the loading diagram of the electric motor there are maxima for which overcoming sufficient reloading ability of the electric drive is required, as a rule, not less than two. This requirement leads to necessity to overestimate the rated capacity of the electric drive.

Abundantly clear, that in decrease in amplitude of fluctuations of the load torque on an electric motor shaft the serious potential of decrease in the rated capacity of the electric drive is concluded. It is simultaneously possible to count on electric power consumption decrease on unit of volume of the extracted oil.

Basic possibility to lower amplitude of fluctuations of the torque on a drive shaft appears, if at lifting of weights on each pumping cycle to use kinetic energy of the same unbalanced weights. Differently, to lower peak of the torque on an electric motor shaft on a pumping cycle it is necessary to admit decrease in speed of movement on a part of this cycle. Effective engineering mean of the decision of such problem of regulation will be the system the frequency converter - the induction motor by which installation is equipped.

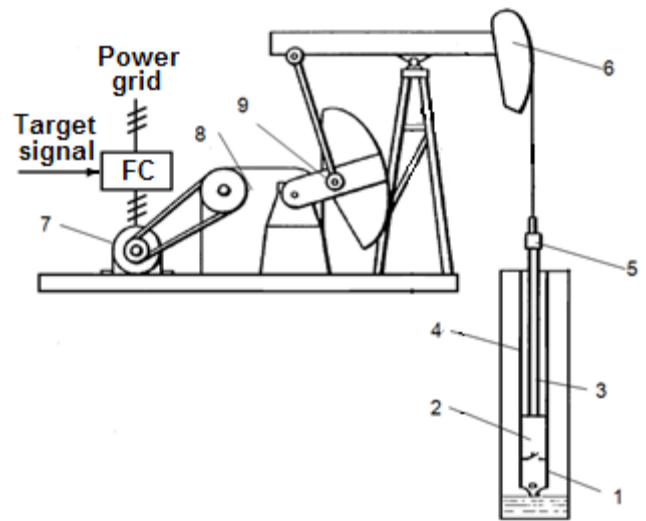

Fig.2. The function scheme of typical sucker-rod pump installation.

As it has already been noted above, compensation of the potential energy  $\Delta W_{pot}$  demanded from the electric drive for lifting unbalanced parts of pump installation, the same quantity kinetic energy  $\Delta W_{kin}$ . This energy can be received for the count of a crank angular speed reduction on value  $\Delta\omega$ . Certainly, it is necessary to provide possibility of the subsequent increase in angular speed of a crank on value  $\Delta\omega$  (restoration of the lost kinetic energy) at lowering of the same unbalanced weights. On fig. 3 presented the corresponding schedule of considered changes of crank angular speed.

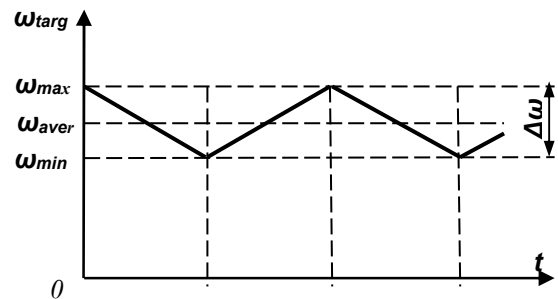

Fig.3. The crank angular speed curves of sucker-rod pump unit

For realization of such schedule it is important to find values of accelerations on sites of angular speed change. We will consider the analytical dependences, allowing to calculate accelerations corresponding to such high-speed mode of sucker-rod pump unit.

It is easy to define, that change of kinetic energy at the expense of reduction of angular speed by value  $\Delta\omega$  is defined by the formula

### III. METHOD REALISATION OF ENERGY EFFICIENT CONTROL OF SUCKER-ROD PUMP INSTALLATION ELECTRIC DRIVE

Let's consider analytical a substantiation of possibility of load torque alignment on a shaft of the electric motor by means of use of kinetic energy of unbalanced moving parts of the oil jack pump.

$$\Delta W_{kin} = J \omega_{aver} \Delta \omega, \quad (1)$$

where:  $J$  - the moment of inertia of unbalanced cargo led to a crank;

$\omega_{aver}$  – average value of angular speed of a crank for a cycle of pumping;

$\Delta \omega$  – change of angular speed of a crank when in use lifting or lowering of bars.

Change of potential energy of unbalanced parts of installation at bars lifting of the pump (on half of a job cycle) is defined by the formula

$$\Delta W_{pot} = 2mgR, \quad (2)$$

where:  $m$  - weight of unbalanced parts of the installation, led to a crank axis,

$g$  - free falling, acceleration,;

$\Delta \omega$  – change of angular speed of a crank when in use lifting or lowering of bars.

From equality of increments potential (2) and kinetic (1) energy it is receive corresponding value of crank rotary speed reduction

$$\Delta \omega = \frac{2mgR}{J \omega_{aver}}. \quad (3)$$

Time of lifting  $t_{lift}$  (lowering  $t_{low}$ ) of bars is defined by size of average angular speed  $\omega_{aver}$ :

$$t_{lift} = t_{low} = \frac{\pi}{\omega_{aver}}. \quad (4)$$

And while, the desired quantity angular acceleration (delay) of a crank at lifting (lowering) of bars is calculated as:

$$\varepsilon = \frac{\Delta \omega}{t_{lift}} = \frac{\Delta \omega \omega_{aver}}{\pi} = \frac{2mgR}{\pi J} \quad (5)$$

Thus, we have come to conclusion, that for realization of alignment of the load torque on the electric motor shaft by means of use kinetic energy it is necessary cyclically to change speed of rotation of a crank with acceleration according to (5). The electric drive (system with frequency converter FC and induction motor) by which sucker-rod pump is equipped will quite overcome with such problem if in a control system to add corresponding «reference unit» of the motor rotation speed.

Except specialized «reference unit» at technical realization of offered cyclic change of speed it is necessary to use the position sensor of a crank which should be established on a crank shaft of sucker-rod pump installation. The sensor can have rather simple design since from it is required only data to within half of turn of a crank.. To lifting of sucker-rod pump installation bars there corresponds turn of an axis of a crank on half of turn, and the subsequent a half-turn correspond to lowering of bars.

On fig.4 a target (reference) signal of crank angular speed curves  $\omega_{targ}$  is represented at cyclic lifting and lowering of bars. And limits of lifting and lowering sectors

are defined by means of a signal of the position sensor, presented on the same fig. 4.

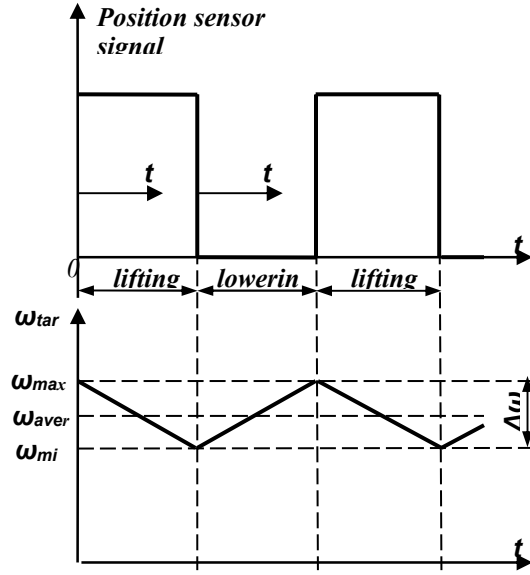

Fig.4. The graphic of set crank rotation speed of sucker-rod pump installation in a combination to a signal of the position sensor of this crank

At lifting of bars the position sensor installed on an axis of crank of sucker-rod pump installation, gives the command on generation the target signal of crank angular speed, according to expression:

$$\omega_{aver} = \omega_{max} - \varepsilon \cdot t_1, \quad (6)$$

where:  $t_1$  – time counted from the moment of the beginning of bars lifting;

$\omega_{max} = \omega_{aver} + \frac{\Delta \omega}{2}$  – target speed for an input of the frequency converter at the moment of the beginning of bars lifting.

At lowering of bars the position sensor gives a command on generation of the target of angular speed on the frequency converter, increasing it according to expression

$$\omega_{targ} = \omega_{min} + \varepsilon \cdot t_2, \quad (7)$$

where:  $t_2$  – time counted from the moment of the begin of bars lowering,

$\omega_{min} = \omega_{aver} - \frac{\Delta\omega}{2}$  – target speed on an input of the frequency converter at the moment of the beginning of bars lowering.

The curve of the target crank angular speed, presented on fig.4, will provide changes of this crank speed in a range in width  $\Delta\omega$  in limits from  $\omega_{max}$  to  $\omega_{min}$ . Thereby the fluctuations of kinetic energy equal to change of potential energy of bars of the sucker-rod pump will be provided. As a result of fluctuation of the sucker-rod pump potential energy are compensated not for the electric power received from a power grid, but for the expense of kinetic energy fluctuations. Thus, use falling bars kinetic energy for their subsequent lifting by a speed control of the motor with certain rate of deceleration is carried out at movement of bars upwards and rate of acceleration at bars downwards movement.

Function scheme of updated sucker-rod pump unit, in which the offered realized, presented on fig. 5. Basic difference of this scheme is application in the electric drive of the computing block CB (PLC) and the position sensor which is installed on a crank shaft of installation. The considered computing block works as specialized «reference unit» of speeds movement of pump bars. It is important, that the algorithm of such reference unit work corresponds to the resulted above relationships and has been coordinated with the sensor of pump bars movement direction.

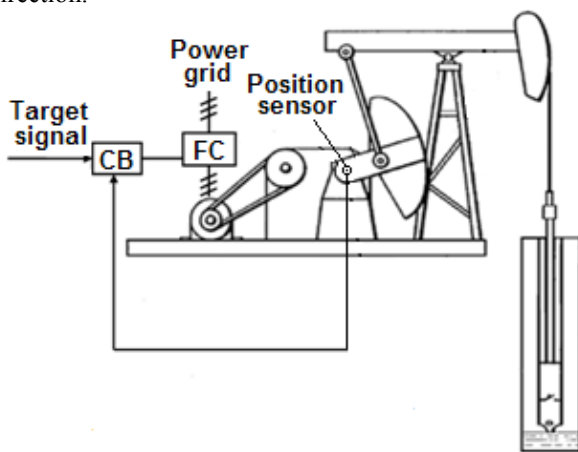

Fig.5. Function scheme of updated sucker-rod pump unit with energy efficient control mode by frequency-regulated electric drive.

Updated scheme works as follows. On an input of the computing block CB (PLC) feed the reference signal of average angular crank speed  $\omega_{aver}$  and the signal from the position sensor. At lifting of a bar of the pump from the position sensor arrives the signal of logic one. Thus the computing block reduces value of a signal of the target of angular speed of crank rotation with constant rate  $\varepsilon$  (fig. 4), and at lowering of a bar of pump from the position sensor the signal of logic zero arrives.

#### IV. CONCLUSION

Having applied the offered improvement of sucker-rod

pump installation it is possible to realize energy efficient control the installation electric drive. Such management leads to decrease in peak values of pulsing loading of the electric drive and decrease energy consumption at the expense of reduction of root-mean-square losses. Use of an offered method leads to reduction of a energy stream which is passing through the converter and the motor that leads to possibility of decrease in their rated capacity.

Let's notice, that on validity of the made conclusions will not affect the account of the electric drive loading called by friction forces at work of unit since the above were analyzed only expenses of energy for moving of unbalanced weights of installation.

It is important to underline, that the offered approach to the electric drive control, which is based on cyclic transformation of potential and kinetic types of energy, can be realized not only in sucker-rod pump unit. The offered method can be effectively applied on any technological installations in which rotary movement of the motor shaft will be transformed to back-and-forth motion of installation unbalanced weights. Examples of such installations are press and forming machines, tilt saws, etc.

The offered method of control is protected by the Patent of the Russian Federation for the invention [9].

#### REFERENCES

- [1] M.I.Khakimyanov, I.N.Shafikov,. The electric power consumption analysis at the mechanised oil-production by electrocentrifugal pumps // Electrotechnical both information complexes and systems. 2013. T. 9. №3. Pp. 37-41.
- [2] Brandt A. R. Oil depletion and the energy efficiency of oil production: The case of California // Sustainability. 2011. T. 3, №. 10. Pp. 1833-1854..
- [3] Vazquez M. et al. Global Optimization of Oil Production Systems A Unified Operational View //SPE Annual Technical Conference and Exhibition. Society of Petroleum Engineers, 2001
- [4] Clemens Langbauer, Thomas Winkler. Frequency elastic drive system operation of sucker rod pumping system. 2018 17th International Ural Conference on AC Electric Drives (ACED) Pages: 1 – 5, IEEE Conferences
- [5] M.I. Khakimyanov, I.N.Shafikov, F.F.Khusainov. Control of sucker rod pumps energy consumption 2015 International Siberian Conference on Control and Communications (SIBCON) Pages: 1 – 4, IEEE Conferences.
- [6] Zyuzev A.M, Bubnov M.V. SRPU Balance Monitoring by Wattmeter Card. 2018 17th International Ural Conference ACED, IEEE, 345 E 47TH ST, New York, NY 10017 USA
- [7] Evgeniy Solodkiy ; Dmitry Dadenkov ; Vladimir Kazantsev. Sensorless energy-efficient sucker-rod pump control system 2018 X International Conference on Electrical Power Drive Systems (ICEPDS) Pages: 1 – 5, IEEE Conferences.
- [8] Marat Khakimyanov ; Fanur Khusainov. Ways Increase of Energy Efficiency of Electric Drives Sucker Rod Pump for Oil Production 2018 X International Conference on Electrical Power Drive Systems (ICEPDS) Pages: 1 – 5. IEEE Conferences
- [9] Patent RF № RU 2 686 304 C1 Metod of control of the jack pump frequency-regulated electric drive with the induction motor / Anatoly N. Ladygin, Dmitry D. Bogachenko, Nikolay A. Ladygin, Vladimir V. Kholin. Bulletin of inventions. 2019. № 5.